

SURE JET
ENVELOPE FINISHING SYSTEM
MODEL EFS

SURE JET VACUUM BASE SJVB
SURE JET VACUUM BASE SJDB-EXT

Parts Manual



SURE-FEED ENGINEERING

12050 49th STREET NORTH - CLEARWATER, FL. 33762-4301
PHONE: 727.571.3330 - FAX: 727.571.3443 - TOLL FREE: 1.800.INSERTER
web: sure-feed.com

TABLE OF CONTENTS

ENVELOPE FINISHING SYSTEM- SURE JET

<u>EFS-SURE JET VACUUM BASE ASSEMBLY</u> (FIG. 1).....	4
FRAME ASSEMBLY (FIG. 2).....	6
CONVEYOR DRIVE ASSEMBLY (FIG. 3).....	8
IDLER SHAFT / TENSIONER ASSEMBLY (FIG. 4).....	10
DRIVE SHAFT ASSEMBLY (FIG. 5).....	12
BELT GUIDE ASSEMBLY (FIG. 6).....	14
DRAG STRIP ASSY (FIG. 7).....	15
VACUUM ASSEMBLY (FIG. 8).....	17
ELECTRICAL ENCLOSURE ASSEMBLY (FIG. 9)	19
CONTROL CONSOLE ASSEMBLY (FIG. 10).....	21
ELECTRICAL BASE ASSEMBLY (FIG. 11A &B).....	23
J BOX ASSEMBLY (FIG. 12)	26
PLUG RECEPTACLE (FIG. 13)	28
<u>EFS-SURE JET DRYER BASE</u> ASSEMBLY	
FRAME ASSEMBLY (FIG. 14)	30
IDLER TENSIONER ASSEMBLY (FIG. 15)	32
IDLER PULLEY ASSEMBLY (FIG. 16)	34
BELT GUIDE ASSEMBLY (FIG. 17)	35
VACUUM ASSEMBLY (FIG. 18)	36

ENVELOPE FINISHING SYSTEM

SURE JET VACUUM BASE

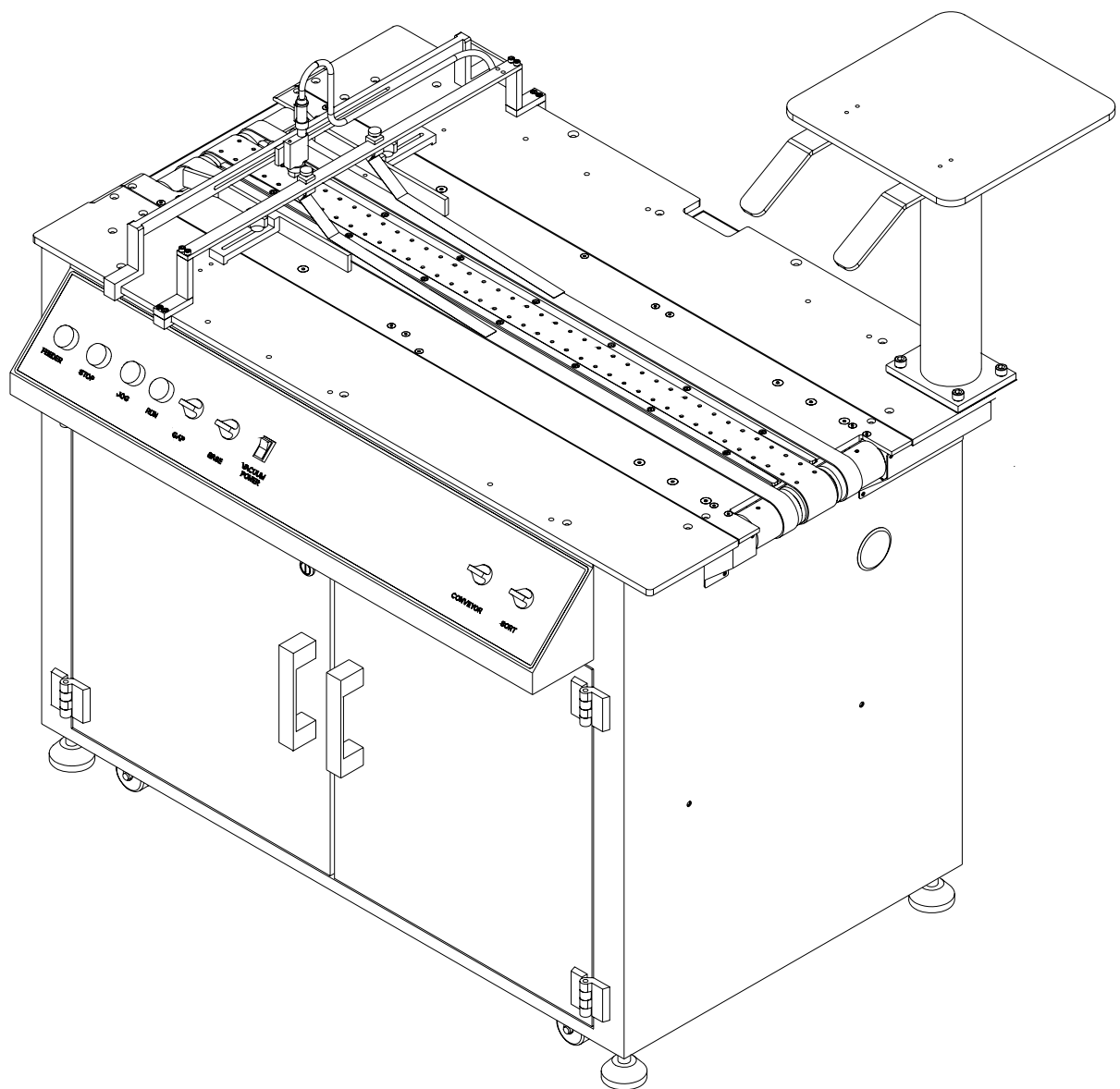

EFS-SURE JET VACUUM BASE ASSEMBLY (Fig. 1)

ITEM	PART NO.	QTY.	DESCRIPTION
1	16020-292	1	FRAME ASSEMBLY (SEE FIG. 2)
2	16020-186	1	CONVEYOR ASSEMBLY (SEE FIG. 3-6)
3	16020-013	1	HOLD DOWN ASSEMBLY (SEE FIG. 7)
4	16020-179	1	VACUUM ASSEMBLY (SEE FIG. 8)
5	16020-293	1	ADJUSTABLE SENSOR ASSEMBLY (SEE FIG. 3)

FIG. 1

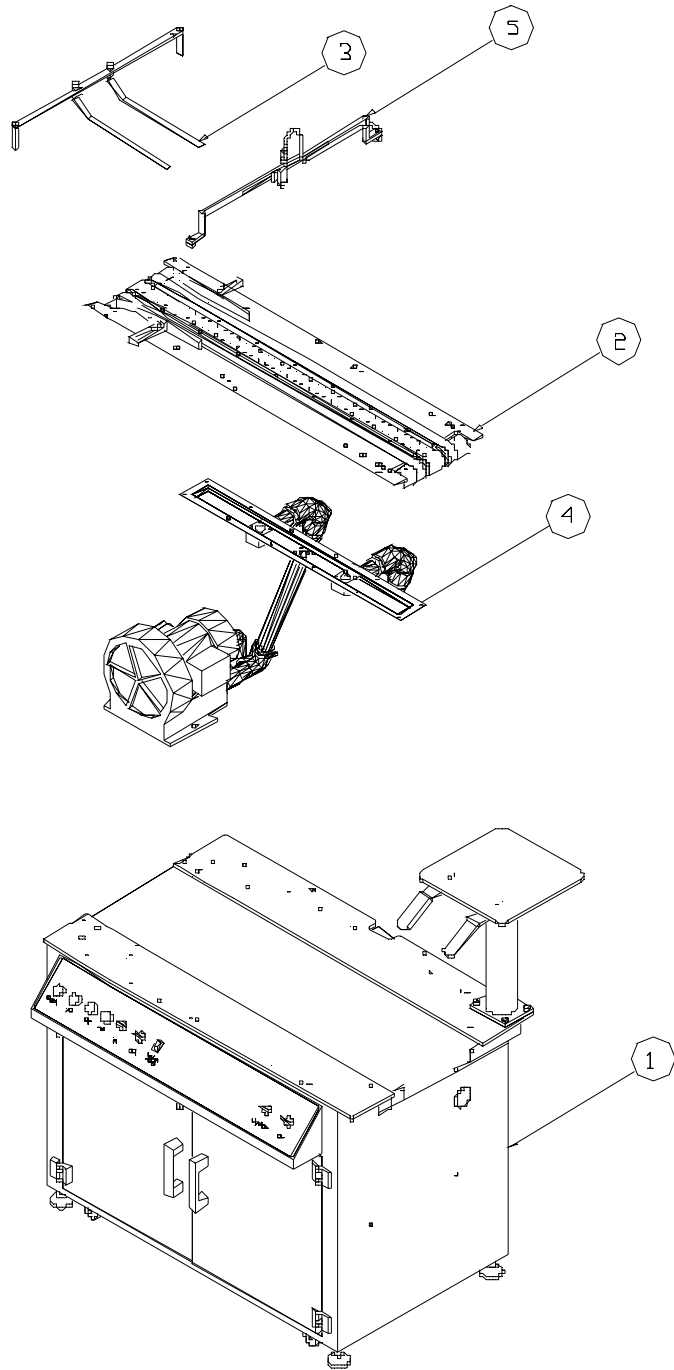

**EFS-SURE JET VACUUM BASE (Fig. 2)
FRAME ASSEMBLY**

ITEM	PART NO.	QTY	DESCRIPTION
REF	16020-292	1	ASSEMBLY, FRAME INKJET BASE
1	16000-035	1	MAIN FRAME, INKJET BASE
2	16013-006	1	DOOR, FRONT, LH (INKJET)
3	16013-005	1	DOOR, FRONT, RH (INKJET)
4	99011-002	4	HINGE, DOOR
5	99013-001	2	LATCH, DOOR
6	16013-013	2	HINGE, ELECTRICAL CONTROL CONSOLE
7	99010-001	4	FOOT, ADJUSTABLE, 5/8-11
8	99010-002	4	CASTER, 2"
9	16013-046	1	COVER, INSIDE, INKJET PANEL
10	16011-061	1	PLATE, INKJET TOP (LH)
11	16011-128	1	PLATE, TOP, FRONT
12	16013-080	1	DOOR, REAR (NOT SHOWN)
13	16013-082	1	COVER, FRONT DRIVE
14	16007-003	4	BLOCK, TOP PLATE SUPPORT
15	99012-004	2	PULL HANDLE
16	16000-003	1	STAND, MONITOR
17	16009-025	2	BRACKET, KEYBOARD SUPPORT
18	99039-123	2	LATCH, CABINET
	16007-082	2	BLOCK, SPLICE STRAP (NOT SHOWN)
REF	16020-013	1	ASSEMBLY, HOLD DOWN (SEE FIGURE 7)
REF	16020-293	1	ASSY, ADJUSTABLE SENSOR (SEE FIGURE 3)
REF	FIG 3: #11	REF	GUIDE, SIDE, LH
REF	FIG 3: #12	REF	GUIDE, SIDE, RH
REF	FIG 3: #13	REF	BLOCK, SIDE GUIDE MTG
REF	FIG 3: #14	REF	KNOB, MALE, 10-24 X 3/4
REF	FIG 3: #15	REF	COVER, TRANSFORMER
REF	FIG 3: #15A	REF	PLATE, PANEL, MOUNTING
REF	FIG 3: #16	REF	BLOCK, TOP PLATE SUPPORT

FIG. 2

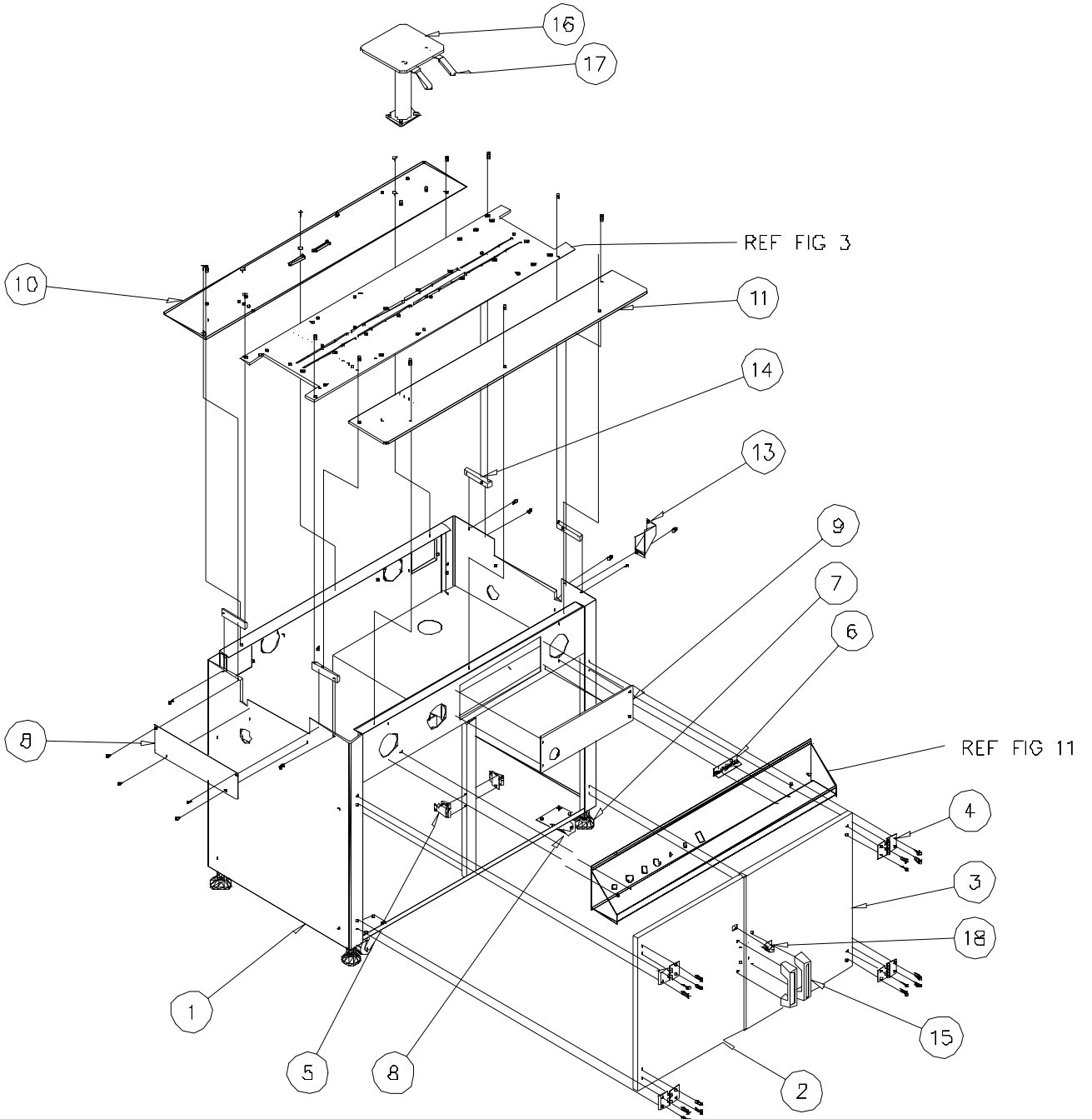

**EFS-SURE JET VACUUM BASE (Fig. 3)
CONVEYOR DRIVE ASSEMBLY**

ITEM	PART NO.	QTY	DESCRIPTION
REF	16020-186	1	ASSEMBLY, CONVEYOR DRIVE
1	16011-062	1	PLATE, INKJET TOP, CENTER
2	16013-055	1	VACUUM CHAMBER
3	16007-053	2	BLOCK, ADAPTER (SEE FIG 8)
4	16014-005	1 SET	BELT, SEAMLESS INKJET
	16007-057	1	BLOCK, ENCODER MOUNTING (NOT SHOWN)
REF	FIG5: #4	REF	BLOCK, BEARING, 5/8
REF	FIG 5: #9	REF	PULLEY, 14XL075 1/2 B W/FLANGE
REF	FIG 5: #5	REF	BELT, TIMING, 100XL075
REF	FIG 5: #10	REF	PULLEY, 22XL075 1/2 B
REF	FIG 8: #23	REF	ADAPTER, MALE, 3/4" NPT X 3/4"
11	12005-010	1	SIDE GUIDE, LH (REF: 16020-292)
12	12005-009	1	SIDE GUIDE, RH (REF: 16020-292)
13	16007-016	2	BLOCK, SIDE GUIDE MTG. (REF: 16020-292)
14	99004-019	2	KNOB, MALE, 10-24 X 3/4 (REF: 16020-292)
	16013-103	1	COVER, TRANSFORMER (REF: 16020-292)
	16001-155	1	PLATE, PANEL, MOUNTING (REF: 16020-292)
REF	FIG 2: #14	4	BLOCK, TOP PLATE SUPPORT (REF: 16020-292)
	16020-293	1	ASSY, ADJUSTABLE SENSOR
17	16007-033	2	BLOCK, CLAMP
18	16007-034	2	BLOCK, SENSOR SUPPORT
19	16007-035	2	BLOCK, SENSOR CLAMP
20	16008-022	1	BAR, SENSOR MTG
21	16011-016	1	PLATE, SENSOR MTG
22	99004-002	2	KNOB, #10 SCREW
	16020-139	1	ASSEMBLY, IDLER / TENSIONER (REF FIG.4)
	16020-063	1	ASSEMBLY, MOTOR DRIVE (REF FIG. 5)
	16020-062	1	ASSEMBLY, BELT GUIDE (REF FIG. 6)

FIG. 3

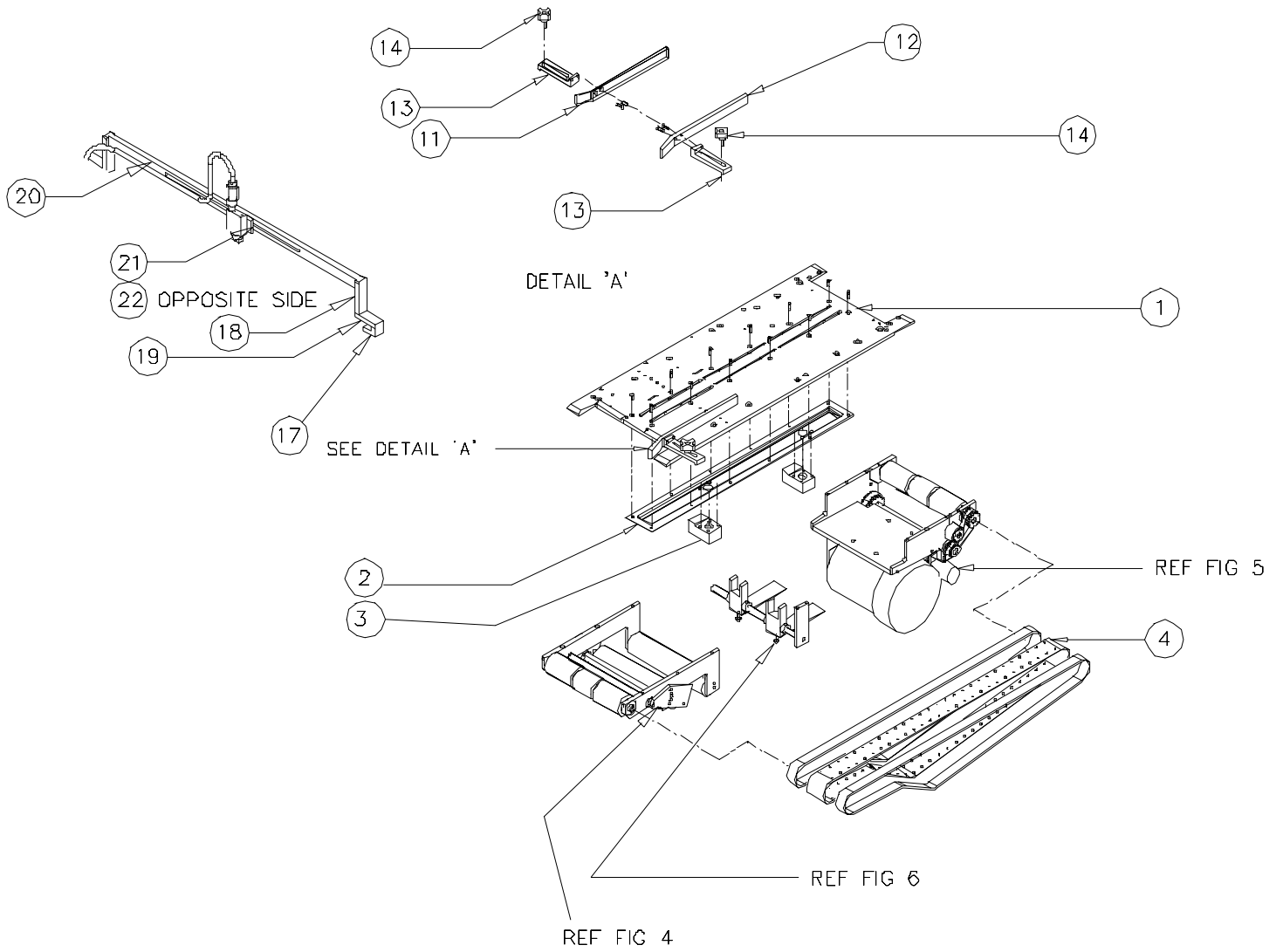

EFS-SURE JET VACUUM BASE – CONVEYOR DRIVE (Fig. 4)
REF:16020-186
IDLER SHAFT / TENSIONER ASSEMBLY

ITEM	PART NO	QTY	DESCRIPTION
	16020-139	1	ASSEMBLY, IDLER PULLEY TENSIONER
1	16007-052	2	BLOCK, BEARING MOUNTING
2	16008-021	2	BAR, IDLER TENSIONER
5	16004-046	1	SHAFT, IDLER
6	16004-045	2	SHAFT, IDLER
7	16004-044	1	SHAFT, ECCENTRIC MOUNTING
8	16006-028	2	ROLLER, ECCENTRIC
9	99003-043	2	BUSHING, FL, 1/2 X 5/8 X 1/2
10	99022-004	4	SNAP RING, 1/2"
11	99036-004	3	SHIM, BEARING, 1/2 X 3/4 X 0.02
3	16020-056	1	ASSY, IDLER PULLEY
	16006-020	1	PULLEY, DRIVE
	16004-028	2	SHAFT, STUB IDLE
	99003-084	2	WASHER, STEEL, 5/8 X 1/16
	99003-051	2	BEARING, 5/8" OD
4	16020-059	2	ASSY, IDLER PULLEY, FIXED
	16006-002	1ea	PULLEY, IDLER 10" FLAT
	99003-007	2ea	BEARING, 1/2" ID X 1-1/8" OD

FIG. 4

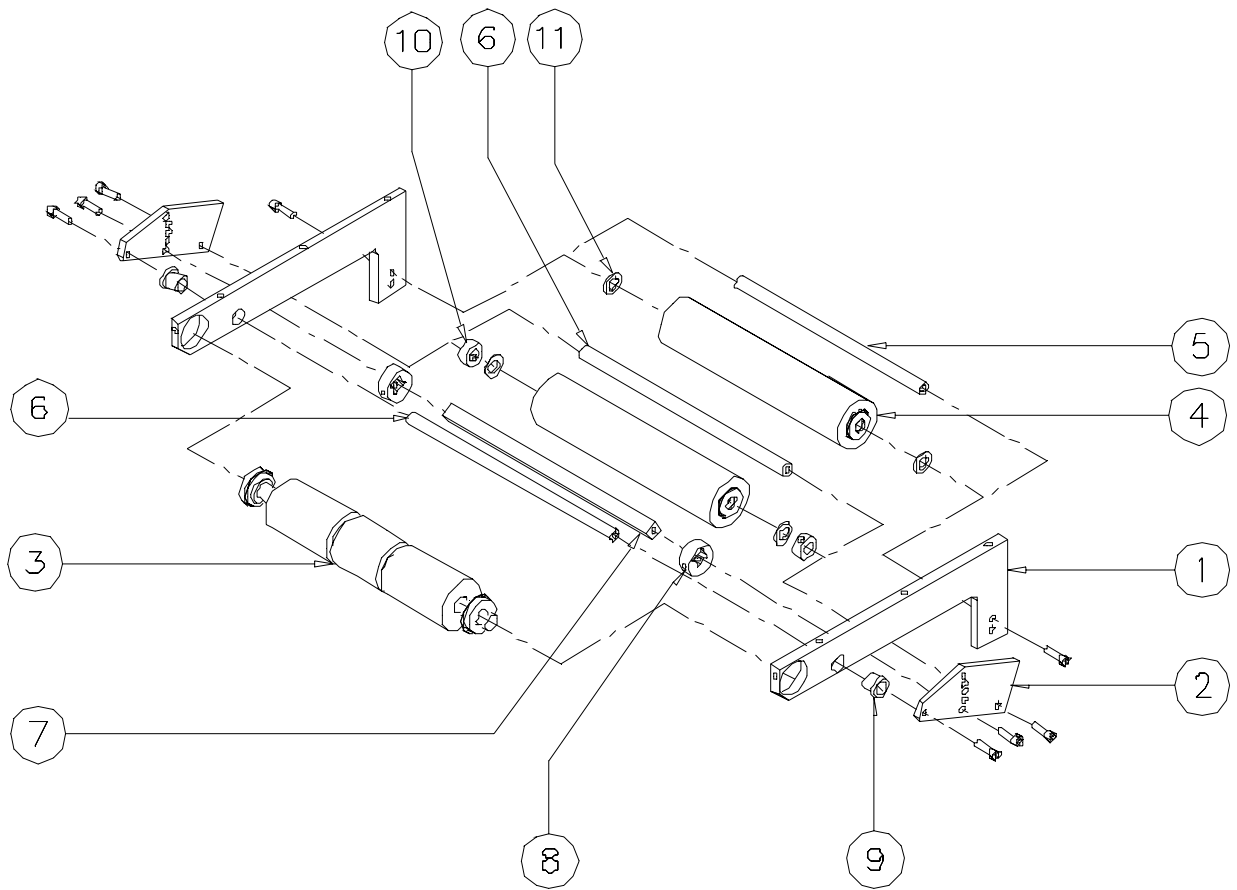

EFS-SURE JET VACUUM BASE – CONVEYOR DRIVE (Fig. 5)
REF: 16020-186
MOTOR DRIVE ASSEMBLY

ITEM	PART NO	QTY	DESCRIPTION
	16020-063	1	ASSEMBLY, MOTOR DRIVE (INKJET BASE)
1	16011-008	1	PLATE, MOTOR MTG.
2	16011-071	2	PLATE, MOTOR MTG SUPPORT
4	16007-056	2	BLOCK, BEARING, 5/8
5	99000-060	1	BELT, TIMING, 100XL075
9	16006-005	1	PULLEY, 14XL075, 1/2B W/FLG
10	16006-006	1	PULLEY, 22XL075, 1/2B
11	16006-109	1	PULLEY, TIMING, 14XL075, 14 MM BORE
12	99001-042	1	MOTOR, 1/2 HP, 1700 RPM, 230/460 3-PHASE
13	99000-059	1	BELT, TIMING, 130XL075
	98010-034	3 ft	CABLE, MOTOR, 14/4 (NOT SHOWN)
	98016-013	1	PLUG, AMP, SERIES 3, 23-7 (NOT SHOWN)
	98016-014	1	BACKSHELL, PLASTIC, SIZE 23 (NOT SHOWN)
	98016-026	4	CONTACT, PIN, 16-12 AWG (NOT SHOWN)
3	16020-055	1	ASSY, INTERMEDIATE DRIVE SHAFT
	16004-010	1	SHAFT, INTERMEDIATE
	99003-051	2	BEARING, 5/8" ID
	99003-084	1	WASHER, STEEL, 5/8 X 1/16
	16006-007	1	PULLEY, 28XL075 5/8 B
	99017-005	1	COLLAR, SHAFT, 5/8
8	16020-054	1	ASSY, DRIVE PULLEY INK JET BASE
	16006-020	1	PULLEY, DRIVE
	16004-027	2	SHAFT, STUB DRIVE
	99003-084	2	WASHER, STEEL, 5/8 X 1/16
	99003-051	2	BEARING, 5/8" OD
REF	16020-092	1	ASSY, TENSIONER INKJET
6	16004-037	1	SHAFT, TENSIONER
7	16006-026	1	PULLEY, IDLER 1" W
14	99003-007	2	BEARING, 1/2" ID X 1-1/8" OD
	99003-018	1	WASHER, STEEL, 1/2" X 1/16
	99022-004	1	SNAP RING, 1/2"
	99003-032	1	WASHER, STEEL, 1/2" X 1/32

FIG. 5

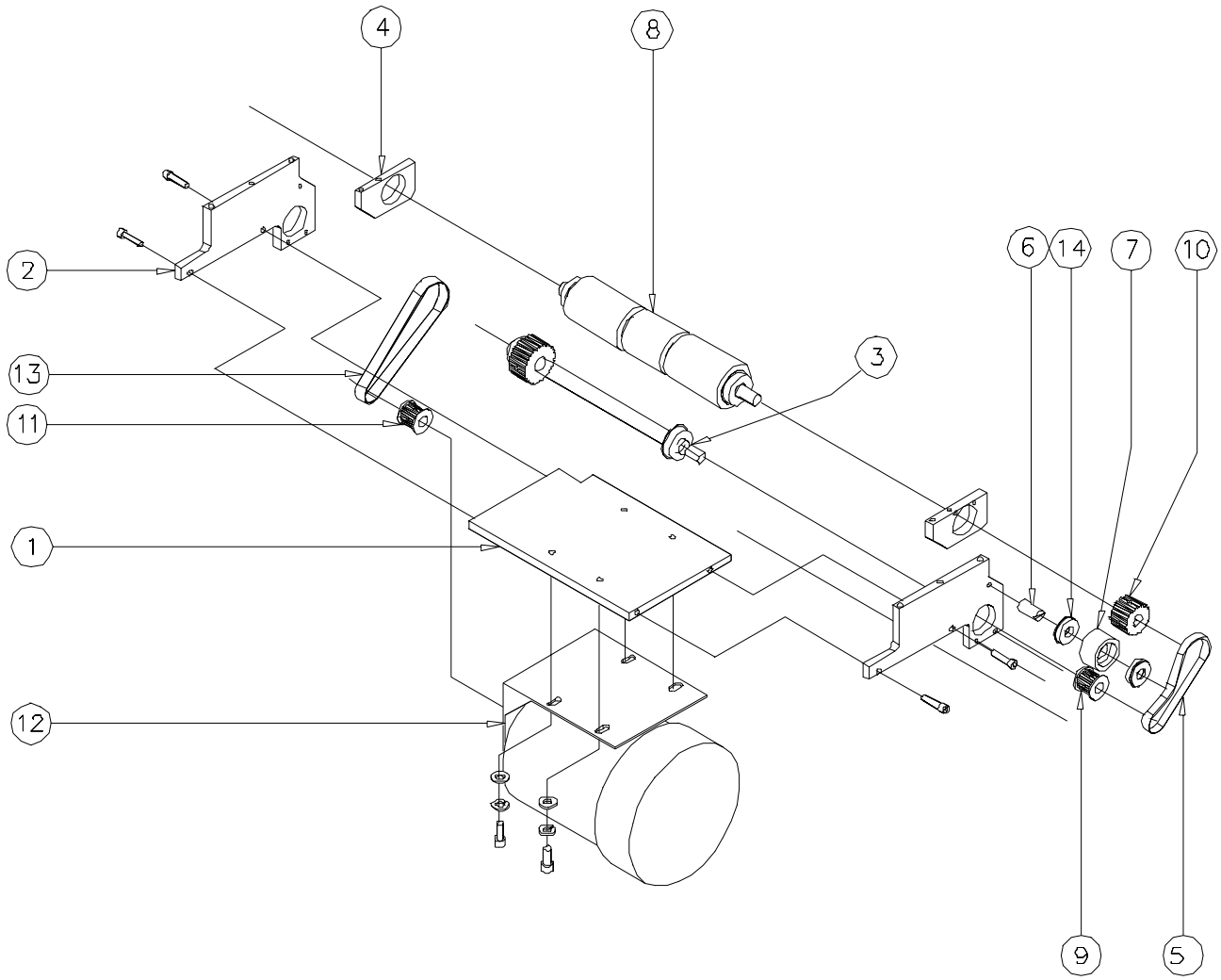

EFS-SURE JET VACUUM BASE – CONVEYOR DRIVE (Fig. 6) BELT GUIDE ASSEMBLY

ITEM	PART NO	QTY	DESCRIPTION
	16020-062	1	ASSEMBLY, BELT GUIDE
1	16009-002	1	BRACKET, BELT GUIDE SUPPORT
2	16005-003	2	GUIDE, BELT , 1"
3	16004-011	1	SHAFT, BELT GUIDE SUPPORT
4	99017-004	4	COLLAR, SHAFT, 1/2"
5	99004-003	2	HANDLE, RATCHET

FIG. 6

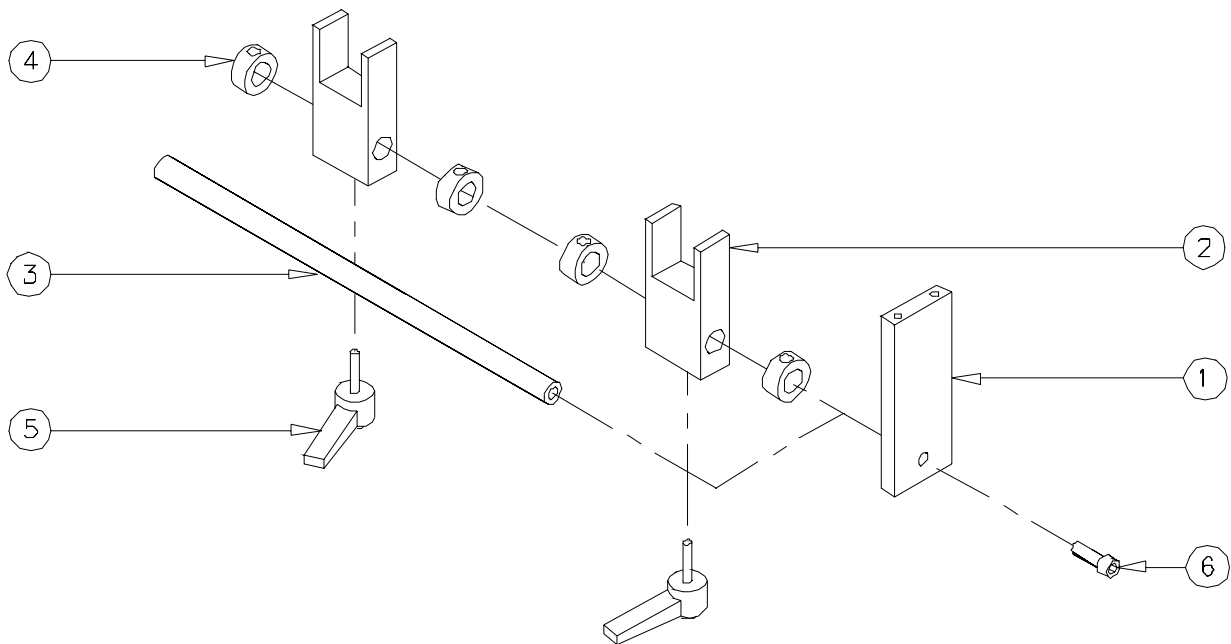

**EFS-SURE JET VACUUM BASE (Fig. 7)
DRAG STRIP ASSEMBLY**

ITEM	P/N	QTY	DESCRIPTION
	16020-013	1	ASSEMBLY, HOLD DOWN INKJET BASE
1	16008-007	1	BAR, DRAG STRIP MOUNTING
2	16009-008	2	BRACKET, DRAG STRIP SUPPORT
3	18009-014	2	BRACKET, DRAG STRIP MOUNTING
4	18009-029	2	BRACKET, DRAG STRIP PIVOT
5	18005-105	2	GUIDE, SPRING STEEL
6		2	SCREW, SKT. HD, 10-24 X 1/2LG W/KNURL'D CAP
7		4	SCREW, SKT.HD, 8-32 X 1/2 LG
8		2	SCREW, SKT.HD, 8-32 X 1/4LG
9		4	SCREW, PAN HD, 6-32 X 1/4LG
10			

FIG. 7

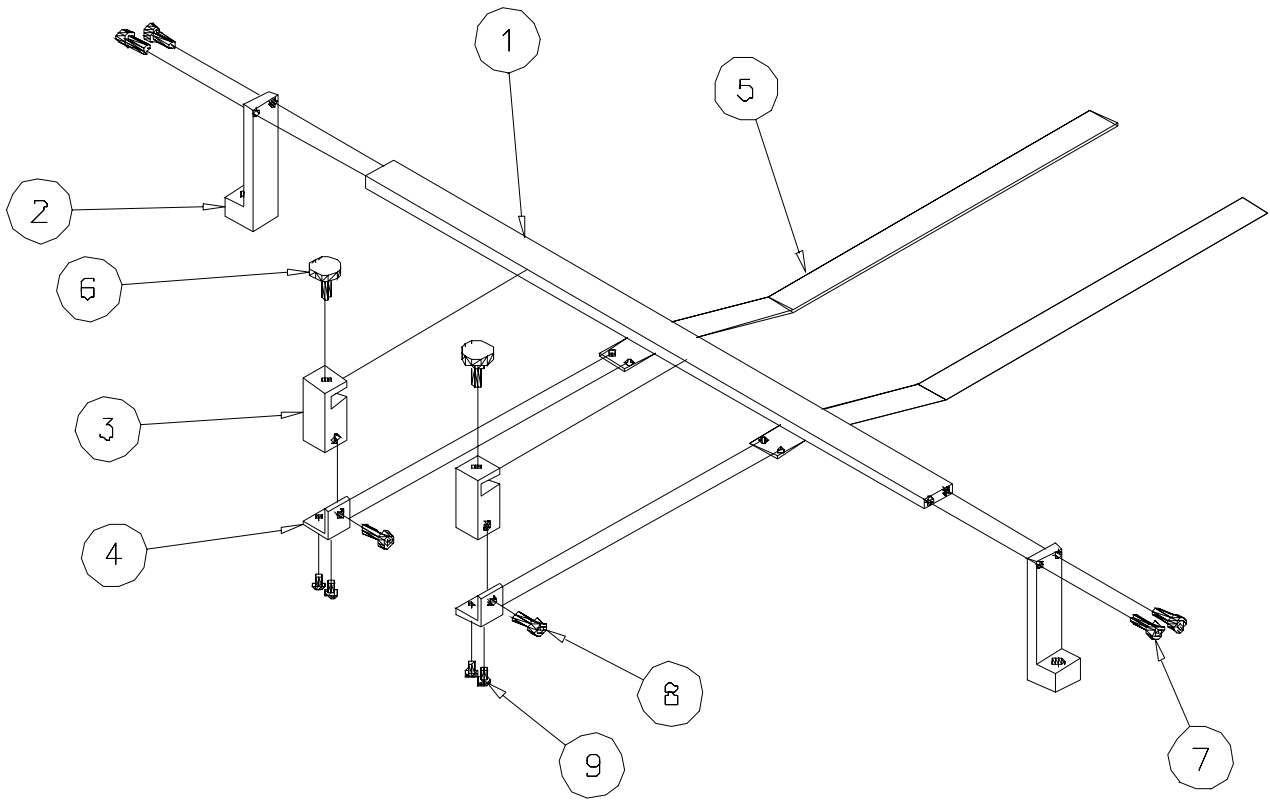

**EFS-SURE JET VACUUM BASE (Fig. 8)
VACUUM ASSEMBLY**

ITEM	PART NO	QTY	DESCRIPTION
	16020-179	1	ASSEMBLY, VACUUM COMPONENTS
1	99029-007	1	BLOWER, VACUUM BUSCH#SB0080 DOHT.UBXX
2	99031-030	50"	HOSE, 1" ID
3	99028-049	1	UNION, PVC 1"
4	99028-079	REF	CAP, END, 1" NPT, PVC-NOT USED
5	90017-042	2	HOSE, CLAMP, SS, 2"
	16020-469	1	ASSY, VACUUM PUMP EXHAUST PVC
6	99028-105	1	ADAPTER, MALE, 1-1/4 NPT X 1-1/4 SLIP, PVC
7	16018-026	1	PIPE, PVC, 1-1/4" X 4"
8	99028-106	1	ELBOW, 90 DEG, 1-1/4 SLIP, PVC
	16020-478	1	ASSY, VACUUM PUMP INTAKE PVC
6	99028-105	1	ADAPTER, MALE, 1-1/4 NPT X 1-1/4 SLIP, PVC
7	16018-026	1	PIPE, PVC, 1-1/4" X 4"
8	99028-106	1	ELBOW, 90 DEG, 1-1/4 SLIP, PVC
9	99028-108	1	REDUCER, 1-1/4 TO 1" SLIP, PVC
10	16018-003	1	PIPE, PVC, 1" X 2.25"
11	99025-024	1	VALVE, VACUUM RELIEF
	16020-476	1	ASSY, PVC, ADAPTER TEE
10	16018-003	2	PIPE, PVC, 1" X 2.25"
12	16018-007	1	PIPE, PVC, 1" X 3.038"
13	99028-112	1	TEE, 1" PVC
14	99028-047	1	ADAPTER, MALE, 1" NPT X 1" SLIP, PVC
	16020-475	1	ASSY, PVC, MANIFOLD
15	16018-001	1	PIPE, PVC, 1" X 2.00"
16	16018-021	1	PIPE, PVC, 1" X 9.50"
17	16018-018	1	PIPE, PVC, 1" X 4.00"
18	99028-052	1	TEE, REDUCING, 1" X 3/4" PVC
19	99028-050	2	ELBOW, 90 DEG, 1", PVC
20	99028-053	1	REDUCER, 1" TO 3/4" SLIP, PVC
21	16018-015	1	PIPE, PVC, 3/4" X 2.07"
22	16018-027	1	PIPE, PVC, 3/4" X 1.735"
23	99028-055	2	ADAPTER, MALE, 3/4" NPT X 3/4" SLIP, PVC

FIG. 8

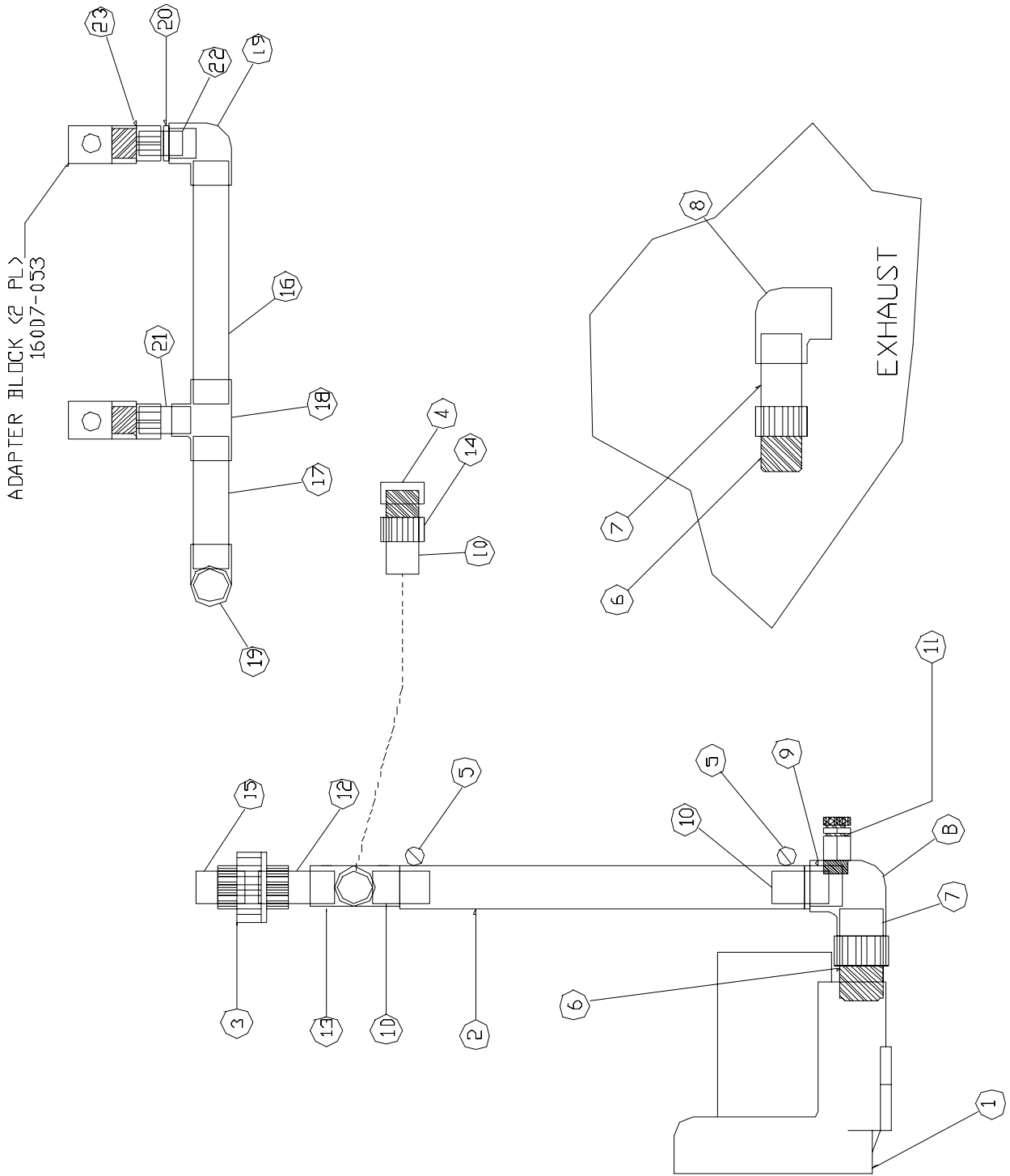

**EFS-SURE JET VACUUM BASE (Fig. 9)
ELECTRICAL ENCLOSURE ASSEMBLY**

ITEM	PART NO	QTY	DESCRIPTION
	16020-510	1	ASSEMBLY, ELECTRICAL ENCLOSURE
1	98015-027	1	GRIP, CORD, ½"
2	98015-029	.3FT	GROMMET EDGING, BLACK
3	98016-009	1	RECEPTACLE, SQ FLG, AMP, 23-7
4	98016-028	4	CONTACT, SOCKET, 16-12 AWG
5	98004-047	4	4A SLO-BLO FUSE
6	98004-023	6	FUSE, 2 A, 250V 5X20MM GDC
7	98004-017	2	FUSE, 1 AMP, 250V, 5X20MM GMC
8	98004-030	1	CIRCUIT BREAKER, 7A, 2 POLE
9	98001-060	41	TERMINAL BLOCK, SPRING
10	98002-005	3	RELAY SOCKET, DPDT
11	98002-007	3	RELAY, DPDT, 24VDC
12	98001-022	3 FT	DIN RAIL
13	980012-008	9 FT	DUCT, WIRE W/COVER, 1" X 3"
14	98002-012	4	RELAY SOCKET, 5 PIN
15	98002-022	1	RELAY, SPST, 120 VAC
16	98002-011	4	RELAY, SPDT, 24VDC
17	98002-032	1	CONTROL RELAY, 24VAC
18	98005-007	2	MOTOR CONTROLLER, 90VDC
19	98006-024	2	POWER RESISTOR, 0.1 Ω
20	98003-016	1	QUADBLOC, TYPE 4752.4200
21	98013-068	2	FR-S520E-0.75K-NA, INVERTER
22	98004-006	2	FUSE, 6A, 225V 5X20MM
23	98001-073	10	BRIDGE, 2 POSITION
24	98010-034	10FT	MOTOR CABLE, 14/4
25	98016-047	1	RECEPTACLE, FREE HANGING, AMP
26	98001-089	4	TERMINAL, DOUBLE LAYER (STTB 2,5)
27	98001-093	2	TERMINAL, DOUBLE LAYER, SHORTED
28	98001-072	4	END STOP TERMINAL
29	98001-064	9	SIDE COVER TERMINAL BLOCK
30	98001-008	2	END COVER, DBL LAYER TERMINAL
31	98001-074	4	BRIDGE, 3 POSITION
32	98001-075	2	BRIDGE, 4 POSITION
33	98004-063	2	FUSE BRIDGE, 20 POSITION
34	98001-063	13	FUSE BLOCK

35	98001-062	3	GROUND TERMINAL
36	98001-061	5	SPRING GROUND TERMINAL
37	98016-216	6	QUICK DISCONNECT, .250 FEMALE
38	98016-218	4	QUICK DISCONNECT, .110 FEMALE
39	98016-219	8	QUICK DISCONNECT, .250 FEMALE
40	98019-068	2	STRAIGHT PRESSURE TONGUE
41	98015-037	7	GROMMET, RUBBER, 7/8"
42	98015-038	3	GROMMET, RUBBER, 1-1/16"
43	16011-045	1	PLATE, PLUG MTG (OMRON)

FIG. 9

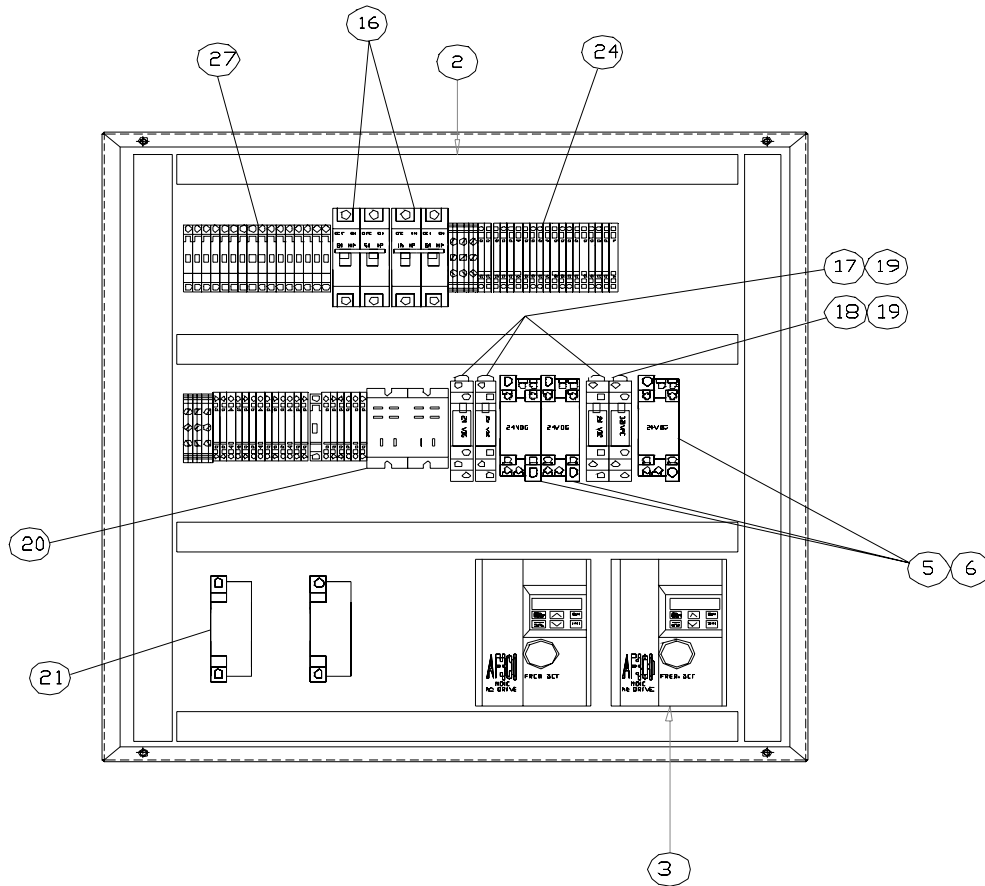

**EFS-SURE JET VACUUM BASE (Fig. 10)
ELECTRICAL CONTROL CONSOLE**

ITEM	PART NO	QTY	DESCRIPTION
	16020-163	1	ASSEMBLY, ELECTRICAL CONSOLE
1	98000-035	1	SWITCH, PUSH BUTTON, BLACK "STOP"
2	98000-038	1	CONTACT BLOCK, N.C.
3	98000-037	2	CLIP SWITCH, ROUND
4	98000-030	1	SWITCH, PUSH BUTTON, GREEN ROUND
5	98000-028	4	CONTACT BLOCK, N.O.
6	98000-027	2	CLIP SWITCH, ROUND
7	98006-036	1	SPEED POT, 10 K
8	98006-007	3	SPEED POT KIT
9	99004-021	4	KNOB, POTENTIOMETER
10	98000-041	1	SWITCH ROCKER, WHITE
11	16013-012	1	CONSOLE ENCLOSURE
12	98000-061	1	SWITCH, PB, MOM, ROUND CLEAR
13	98000-060	1	LAMP HOLDER MODULE
14	98000-031	1	SWITCH, PB MOM, YELLOW ROUND
15	16015-007	1	LABEL, INKJET CONSOLE
16	98022-009	1	LED BULB
17	98006-035	4	KNOB LOCK
	98016-100	1	RECEPTACLE, FREE HANGING, 14 PIN
	98016-092	1	PLUG, AMP, 17-14 REV (MALE)
	98016-005	2	BACKSHELL, PLASTIC SIZE 11
	98016-027	10	CONTACT, SOCKET, 24-20 AWG
	98016-025	10	CONTACT, PIN, 24-20 AWG
	98010-074	7 FT	CABLE, SHIELDED, 18/3
	98010-075	17FT	CABLE, SHIELDED, 22/3
	98010-119	10FT	CABLE, SHIELDED, 22/4

FIG. 10

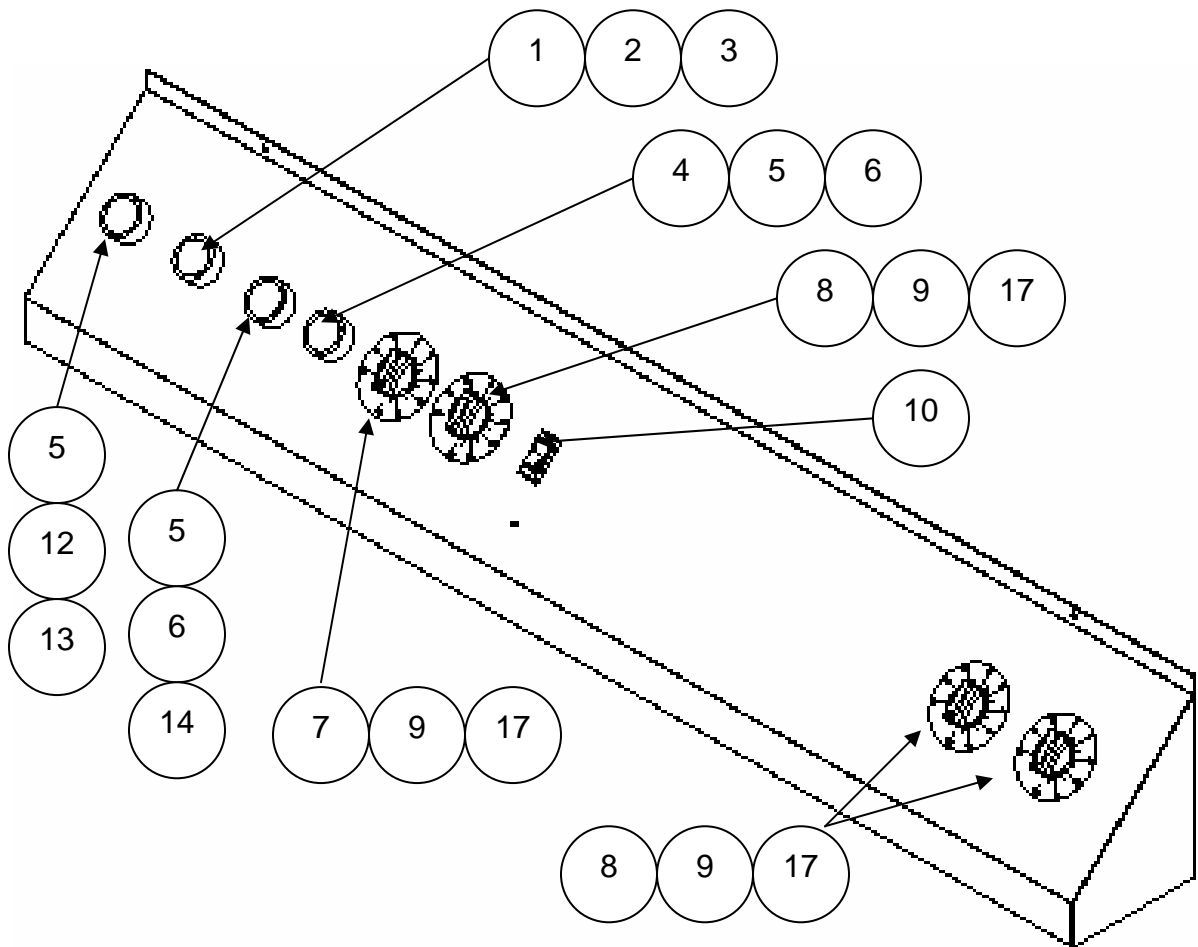

NOTE: ADDED TO THIS DRAWING ONLY--
6/7/07 TLL

17

**EFS-SURE JET VACUUM BASE (Fig. 11A & B)
ELECTRICAL ASSEMBLY**

ITEM	PART NO	QTY	DESCRIPTION
	16020-160	1	ASSEMBLY, INKJET BASE, ELECTRIC
1	^a 98020-023	1	FILTER-30A, 115/250V
2	98003-018	1	RECEPTACLE, HUBBLE TWIST LOCK
3	Fig5:	REF	PLUG, 23-7 PIN MALE(PIN)
4	Fig5:	REF	BACKSHELL, PLASTIC, 7 PIN, SIZE 23
5	Fig5:	REF	CABLE, MOTOR, 14/4
6	98003-017	1	PLUG, HUBBLE TWIST LOCK 20A
7	98016-015	2	BACKSHELL, PLASTIC, SIZE 11
8	98016-046	1	PLUG, AMP, 11-8 STD (FEMALE)
9	98016-145	8	CONTACT, GOLD SOCKET, 20-24 AWG
10	98015-002	1	STRAIN RELIEF, 3/4"
11	98010-186	18 FT	WIRE, 12/3 HAR EXPORT BLACK
12	98010-182	17 FT	WIRE, 16/3, HAR EXPORT BLACK
13	98010-012	8 ft	CABLE, BELDEN, B9934-060
14	Fig5:	REF	CONTACT, PIN 16-12 AWG
15	98016-117	3	CONTACT, SOCKET 26-24 AWG
16	98015-004	1	LOCK NUT, 3/4"
17	98010-074	6 FT	CABLE, SHIELDED, 18/3
18	98016-114	3	CONTACT, PIN, 26-24 AWG
19	98001-067	13	SCREW TERMINAL, 10 GA
20	98008-011	1	TRANSFORMER, 110V
21	98004-044	1	CIRCUIT BREAKER, 20A
22	98001-079	1	TERMINAL END PLATE
23	98001-062	3	GROUND TERMINAL
24	98001-101	2	RAIL ADAPTOR
25	98001-022	2 FT	DIN RAIL
	16020-535	1	E-STOP ASSEMBLY
	98000-016	2	SWITCH, PUSH-PULL STOP
	98000-037	2	CLIP, SWITCH
	98000-038	4	CONTACT BLOCK, N.C.
	98000-028	2	CONTACT BLOCK, 1XNO, PROTECTED
	98000-053	2	E-STOP PLATE, SMALL (TUV)

FIG. 11A

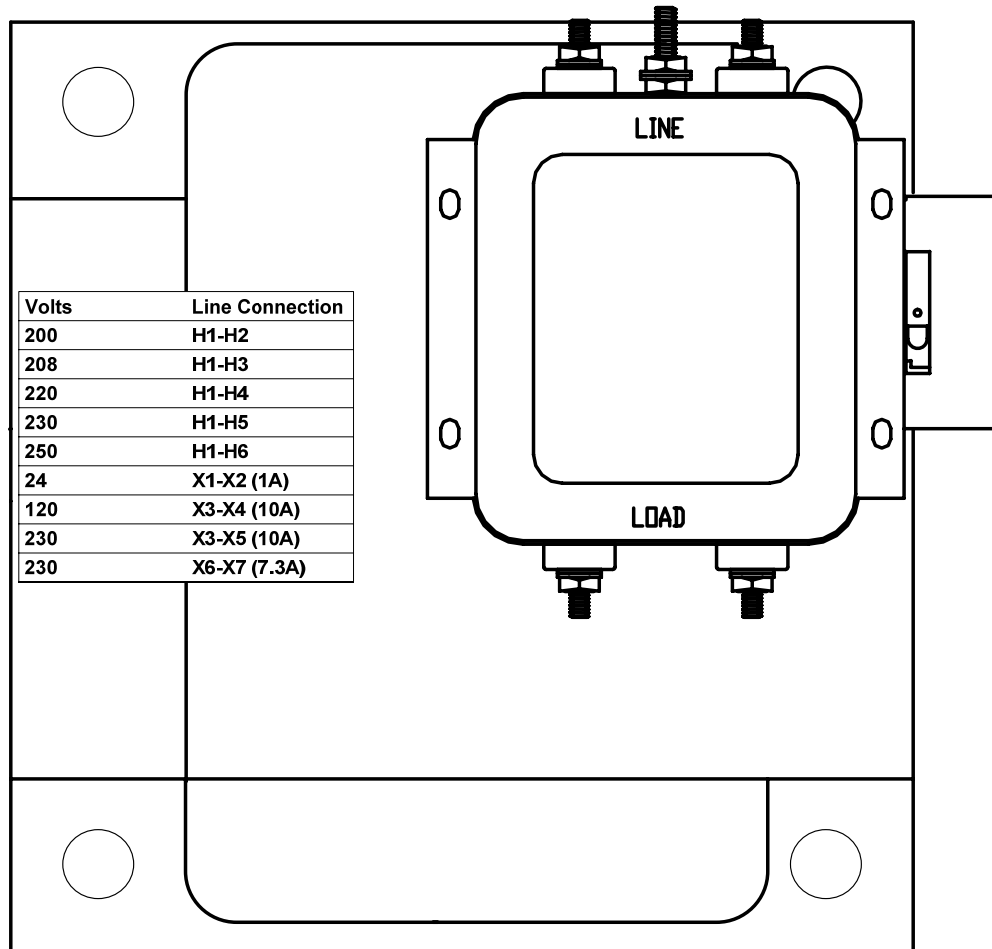
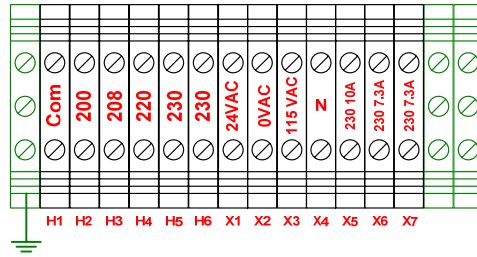
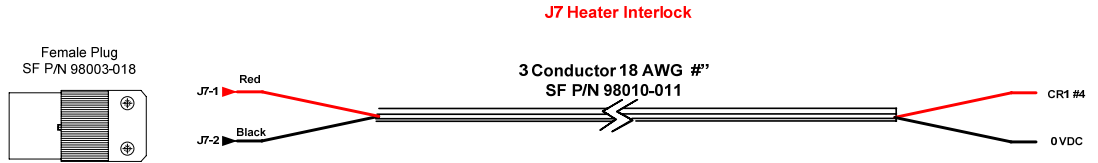
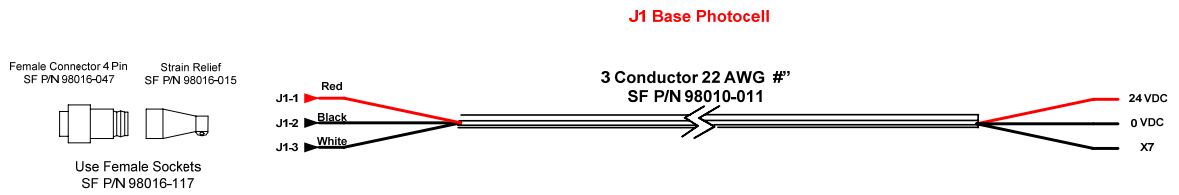
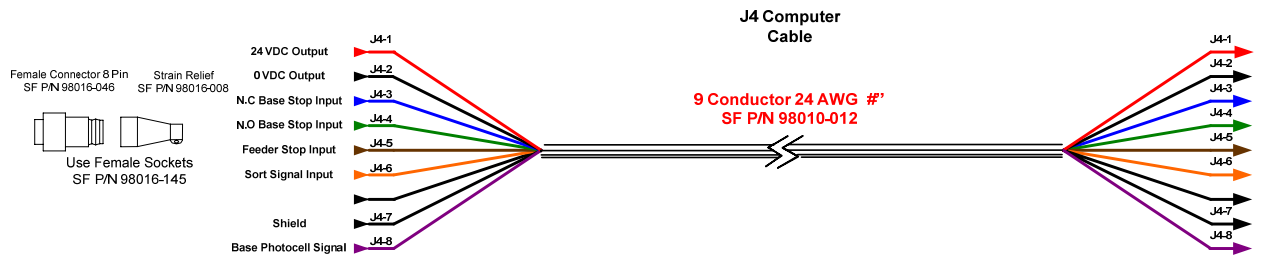

FIG. 11B



**EFS-SURE JET VACUUM BASE (Fig. 12)
J-BOX ASSEMBLY**

ITEM	PART NO	QTY	DESCRIPTION
	16020-162	1	ASSEMBLY, J-BOX
1	98015-002	1	STRAIN RELIEF, 3/4"
2	98001-062	2	GROUND TERMINAL
3	98001-060	16	SPRING TERMINAL BLOCK
4	98001-013	3	GROUND TERMINAL, SPRING
5	98001-063	5	FUSE BLOCK
6	98001-064	2	SIDE COVER, TERMINAL BLOCK
7	98004-017	5	FUSE, 1 AMP, 250V, 5X20MM GMC
8	98004-022	1	FUSE, 500 mA, 250v, 5x20MM GM
9	98001-072	4	TERMINAL, END STOP
10	98001-026	3	CIRCUIT DIVIDER
11	98001-065	2	JUMPER, 3 POLE, TERMINAL BLOCK
12	98001-022	1 FT	DIN RAIL
13	980012-003	4 ft	DUCT, WIRE W/COVER, 1" X 3"
14	^a 98013-054	1	PLC, FX1N
15	98015-004	1	LOCKNUT, 3/4"
16	98001-028	24	TERMINAL, SINGLE 50A 600V
17	98011-007	1	POWER SUPPLY
18	16013-088	1	COVER, ENCLOSURE, J-BOX
19	16013-087	1	ENCLOSURE, J-BOX
20	16011-155	1	PLATE, PANEL MOUNTING
21	98001-073	2	BRIDGE, 2 POSITION
22	98001-074	1	BRIDGE, 3 "
23	98001-075	1	BRIDGE, 4 "
24	98001-076	1	BRIDGE , 5 POSITION

FIG. 12

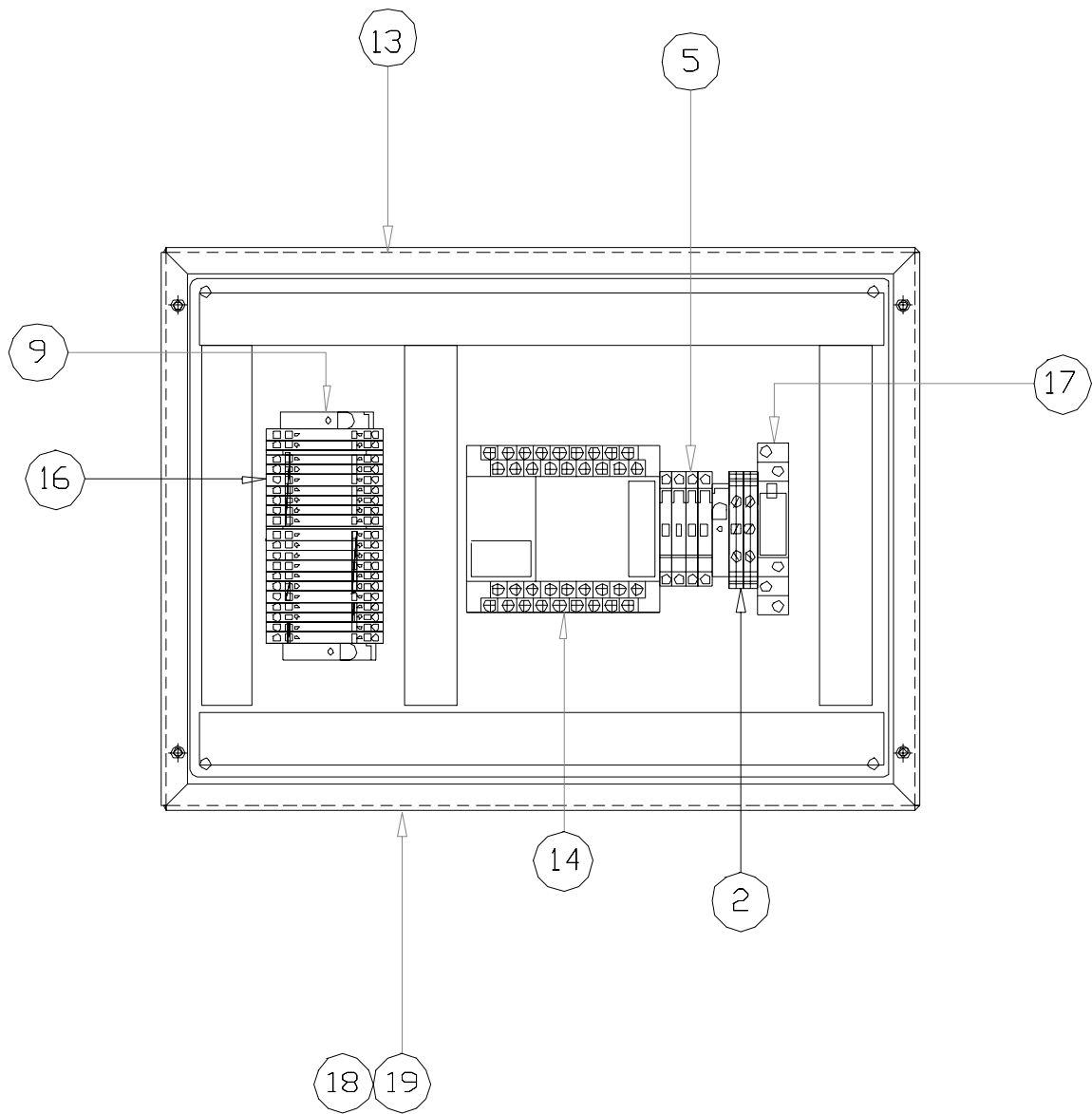

**EFS-SURE JET VACUUM BASE (Fig. 13)
PLUG RECEPTACLE ASSEMBLY**

ITEM	PART NO	QTY	DESCRIPTION
	16020-159	1	ASSEMBLY, PLUG RECEPTACLE
1	98016-154	2	FEMALE 1-16 HC-A-16-EBUS
2	98016-156	2	FEMALE 17-32 HC-A-16-EBUS-32
3	98016-158	2	HOOD HC-D-50-AMQ
4	98016-159	2	HC-D 50-SD-FQ/FS
5	16011-142	2	PLATE, PLUG MOUNTING
6			

FIG. 13

REV	DATE	BY	REVISION NOTE
a	6/7/07	TLL	Corrected P/N 98020-023 from 99020-023 (typo error)
	6/7/07	TLL	Revised P/N 98013-054 from 98003-054 (obsolete)

ENVELOPE FINISHING SYSTEM

SURE JET DRYER BASE

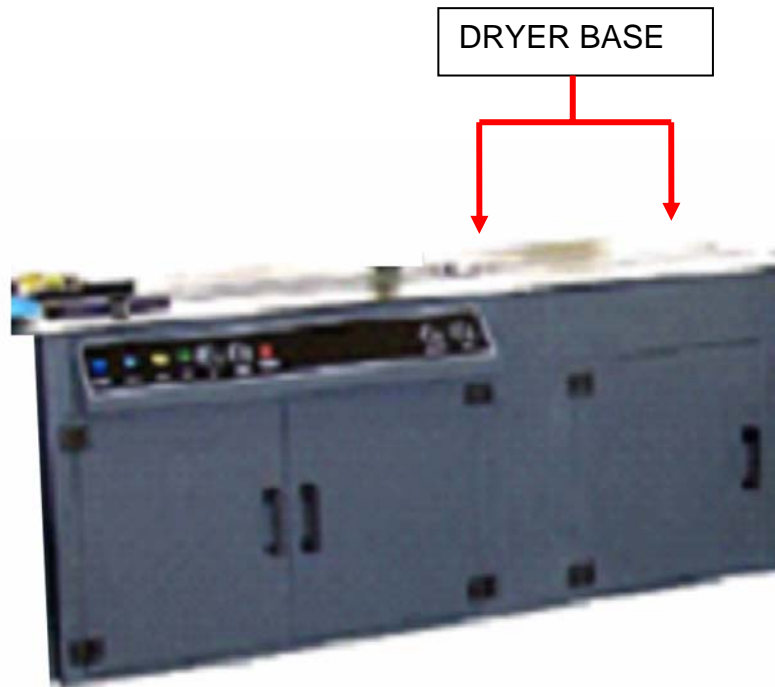

DRYER BASE ASSEMBLY

ITEM	PART NO.	QTY.	DESCRIPTION
	16020-533	1	FRAME ASSEMBLY SEE FIG. 14
	16020-318	1	IDLER TENSIONER ASSY SEE FIG. 15
	16020-319	1	IDLER PULLEY ASSEMBLY SEE FIG. 16
	16020-062	1	BELT GUIDE ASSEMBLY SEE FIG. 17
	16020-534	1	VACUUM ASSEMBLY SEE FIG. 18

**SURE JET DRYER BASE (Fig. 14)
FRAME ASSEMBLY**

ITEM	PART NO.	QTY	DESCRIPTION
REF	16020-533	1	ASSEMBLY, FRAME
1	16000-054	1	DRYER BASE
2	16013-051	1	DOOR, FRONT, LH
3	99012-001	1	DOOR HANDLE
4	99011-002	2	HINGE, DOOR
5	99013-001	2	LATCH, DOOR
6			
7	99010-001	4	FOOT, ADJUSTABLE, 5/8-11
8	99010-002	4	CASTER, 2"
9	99039-034	1	LOCK, ENCLOSURE
10	16011-028	1	PLATE, DRYER TOP (LH)
11	16011-027	1	PLATE, DRYER TOP (RH)
12	16012-003	4	STANDOFF, HI-TEMP
13	16007-021	2	BLOCK, DRYER SUPPORT
14	16007-014	4	BLOCK, TOP PLATE SUPPORT
15	16011-078	1	PLATE, DRYER BASE TOP, CENTER
16	16014-007	1set	BELT, SET SEAMLESS DRYER
17	16013-063	1	VACUUM PLATE
18	16007-053	1	BLOCK, ADAPTER, VACUUM CHAMBER
	16007-082	2	BLOCK, SPLICE STRAP (NOT SHOWN)

FIG. 14

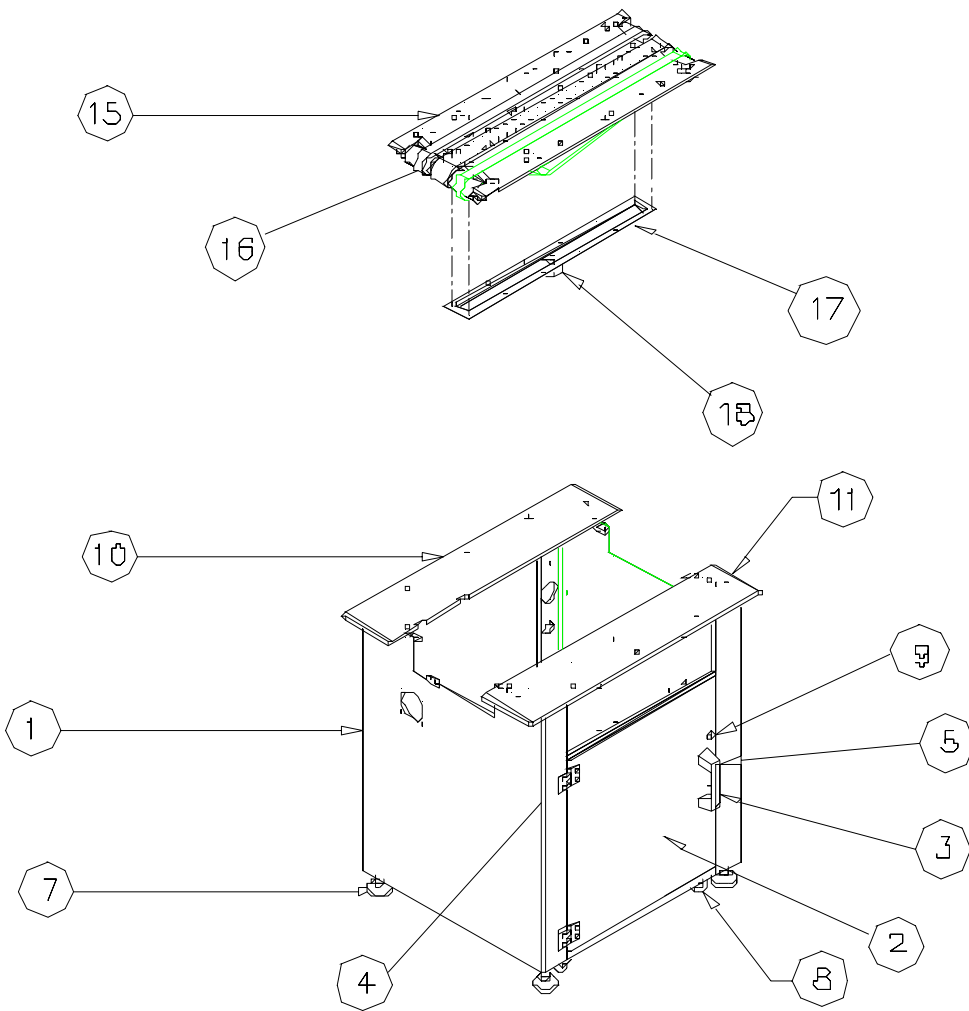

**SURE JET DRYER BASE – (Fig. 15)
IDLER TENSIONER ASSEMBLY**

ITEM	PART NO	QTY	DESCRIPTION
	16020-318	1	ASSEMBLY, IDLER TENSIONER
1	16007-052	2	BLOCK, BEARING MOUNTING
2	16008-002	2	BAR, IDLER
3	16020-314	1	ASSY, DRIVE PULLEY
	16006-020	1	PULLEY, DRIVE
	16004-027	2	SHAFT, STUB IDLE
	99003-084	2	WASHER, STEEL, 5/8 X 1/16
	99003-114	2	BEARING, 5/8" OD
4	16020-315	2	ASSY, IDLER PULLEY, FIXED
	16006-002	1ea	PULLEY, IDLER 10" FLAT
	99003-115	2ea	BEARING, 1/2" ID X 1-1/8" OD
5	16004-046	1	SHAFT, IDLER
6	16004-045	2	SHAFT, IDLER
7	16004-044	1	SHAFT, ECCENTRIC MOUNTING
8	16006-028	2	ROLLER, ECCENTRIC
9	99003-043	2	BUSHING, FL, 1/2 X 5/8 X 1/2
10	99022-004	4	SNAP RING, 1/2"
11	99036-004	3	SHIM, BEARING, 1/2 X 3/4 X 0.02
12	16006-009	2	PULLEY, 18XL075 1/2 B W/FLANGE
13	99000-064	1	BELT, TIMING 90XL075

FIG. 15

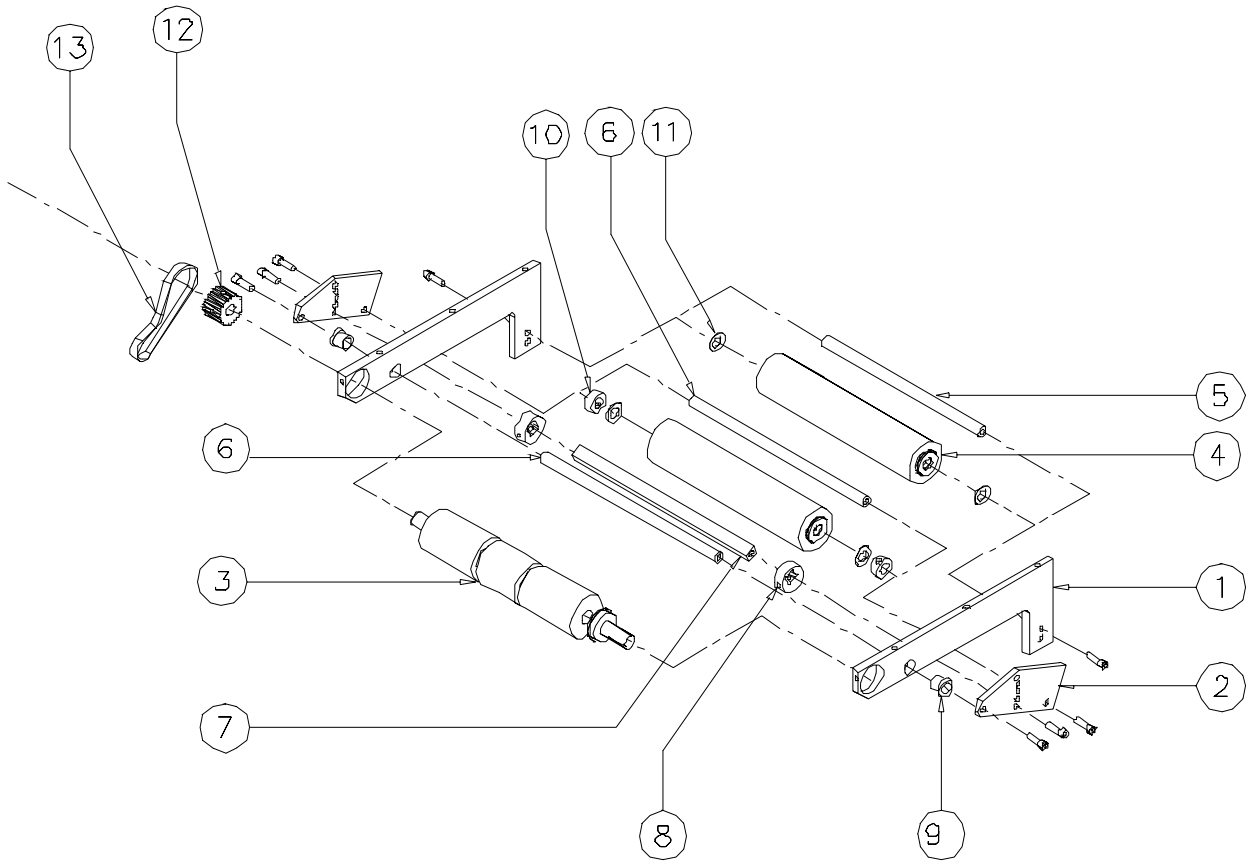

SURE JET DRYER BASE (Fig. 16)
IDLER PULLEY ASSEMBLY
(DISCHARGE END)

ITEM	PART NO	QTY	DESCRIPTION
	16020-319	1	ASSEMBLY, IDLER PULLEY
1	16006-020	1	PULLEY, DRIVE
2	16004-028	2	SHAFT, STUB IDLE
3	99003-114	2	BEARING, 5/8 X 1-3/8, W/SNAP RING
4	99003-084	2	WASHER, STEEL, 5/8 X 1/16
5	16007-056	2	BLOCK, BEARING, 5/8 (NOT SHOWN)

FIG. 16

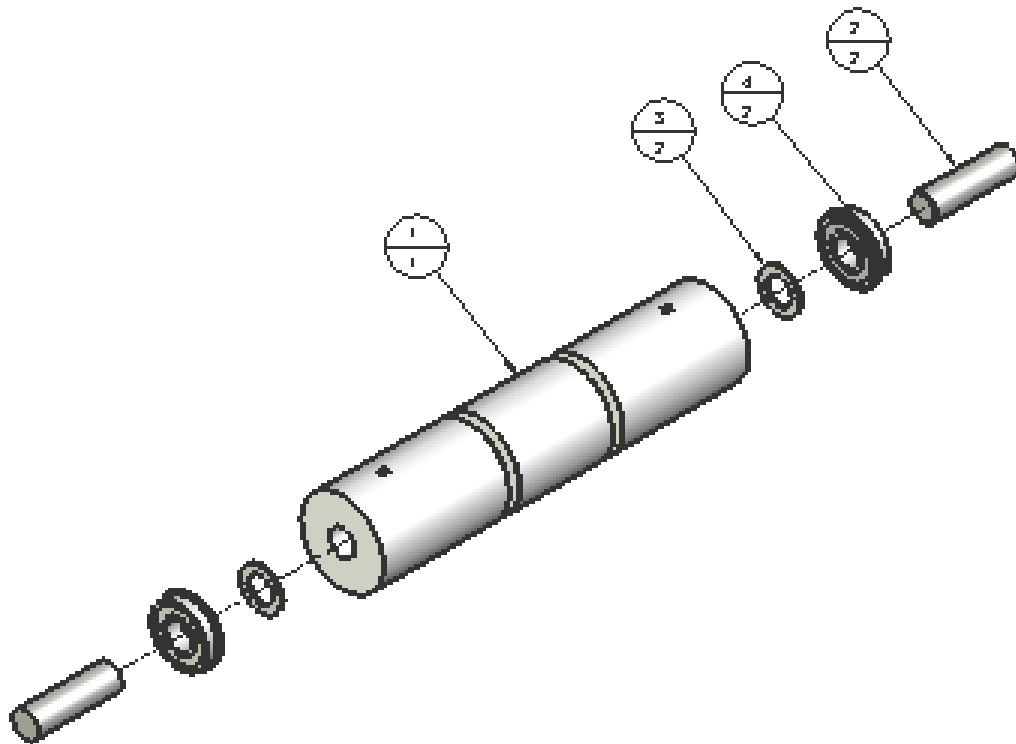

SURE JET DRYER BASE – (Fig. 17) BELT GUIDE ASSEMBLY

ITEM	PART NO	QTY	DESCRIPTION
	16020-062	1	ASSEMBLY, BELT GUIDE
1	16009-002	1	BRACKET, BELT GUIDE SUPPORT
2	16005-003	2	GUIDE, BELT , 1"
3	16004-011	1	SHAFT, BELT GUIDE SUPPORT
4	99017-004	4	COLLAR, SHAFT, 1/2"
5	99004-003	2	HANDLE, RATCHET

FIG. 17

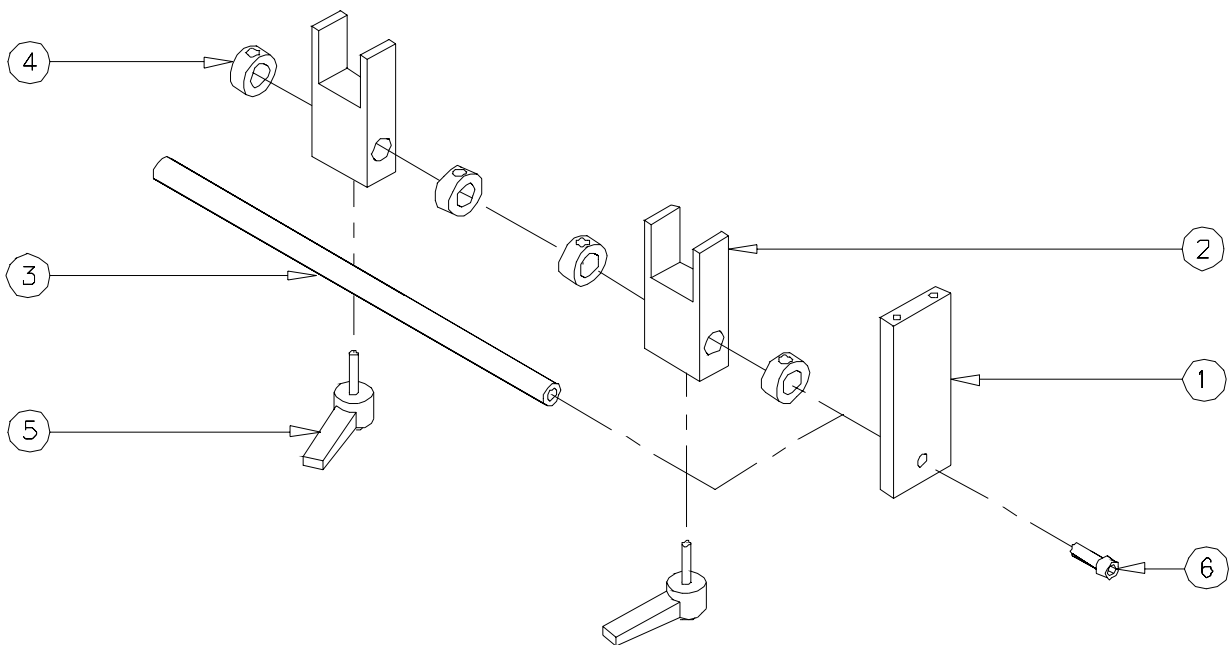

**SURE JET DRYER BASE (Fig. 18)
VACUUM ASSEMBLY**

ITEM	PART NO	QTY	DESCRIPTION
	16020-534	1	ASSEMBLY, VACUUM COMPONENTS
1	99028-057	1	NIPPLE, BRASS 3/4 NPT X 4"
2	99028-058	1	ELBOW, BRASS 3/4
3	16018-013	1	NIPPLE, BRASS 3/4 NPT X 2"
4	99031-006	12"	HOSE, 1" ID, SILICONE
5	99017-030	2	CLAMP, HOSE, SS
6	99028-049	1	UNION, PVC 1"
	16020-472	1	DRYER VACUUM ASSEMBLY
7	16018-003	1	PIPE, PVC, 1" x 2.25"
8	99028-050	1	ELBOW, PVC, 1"
9	16018-	1	PIPE, PVC, 1" X 13"
	16020-473	1	DRYER ADAPTER VACUUM LINE ASSEMBLY
10	16018-036	1	PIPE, PVC, 1' X 24" LG
11	99028-095	1	FEMALE ADAPTER, 1" NPT X SLIP,PVC

FIG. 18

